

Patons
Canadiana

Patons
DECOR



GARTER AND CABLES JACKET

SIZES

Bust measurement

Small 30-32 ins [76-81 cm]

Medium 34-36 ins [86-91 cm]

Large 38-40 ins [97-102 cm]

Extra-Large

42-44 ins [107-112 cm]

Finished bust

Small 42½ ins [108 cm]

Medium 45½ ins [115.5 cm]

Large 47 ins [119.5 cm]

Extra-Large

48½ ins [123 cm]

MATERIALS

Patons Canadiana (100 g/3.5 oz)

or **Patons Décor** (100 g/3.5 oz)

Size S M L XL

9 9 10 10 **balls**

Sizes 4 mm (U.S. 6) and 4.5 mm (U.S. 7) knitting needles **or size needed to obtain tension.** Cable needle. 5 buttons.

TENSION

20 sts and 26 rows = 4 ins [10 cm] with larger needles in stocking st.

ABBREVIATIONS

C2F = slip next st onto a cable needle and leave at front of work. K1, then K1 from cable needle.

C2B = slip next st onto a cable needle and leave at back of work. K1, then K1 from cable needle.

C6F = slip next 3 sts onto a cable needle and leave at front of work. K3, then K3 from cable needle.

C6B = slip next 3 sts onto a cable needle and leave at back of work. K3, then K3 from cable needle.

INSTRUCTIONS

The instructions are written for smallest size. If changes are necessary for larger sizes the instructions will be written thus ().

BACK

With smaller needles, cast on 102 **(108-112-114)** sts.

1st row: (WS). Knit.

Cont in garter st (knit every row) until work from beg measures 2 ins [5 cm] ending with RS facing for next row and inc 30 **(32-32-34)** sts evenly across last row. 132 **(140-144-148)** sts.

Change to larger needles and proceed in pat as follows:

1st row: (RS). (K1. P1) 1 **(3-4-5)** time(s). P1. *K1. P1. C2B. C2F. P1. K1. P1. K12. P1.* K1. P1. C2B. C2F. P1. K1. P2. (K1. P1) twice. P1. Rep from * to * twice. K1. P1. C2B. C2F. P1. K1. P2. (K1. P1) twice. P1. Rep from * to * once. K1. P1. C2B. C2F. P1. K1. P1. (P1. K1) 1 **(3-4-5)** time(s).

2nd and alt rows: (K1. P1) 2 **(4-5-6)** times. *K1. P4. K1. P1. K1. P12. K1. P1.* K1. P4. (K1. P1) 5 times. Rep from * to * twice. K1. P4. (K1. P1) 5 times. Rep from * to * once. K1. P4. K1. (P1. K1) 2 **(4-5-6)** time(s).



ABBREVIATIONS: www.patonsyarns.com/glossary

3rd row: (K1. P1) 1 (3-4-5) time(s). P1. *K1. P1. C2F. C2B. P1. K1. P1. C6B. C6F. P1.* K1. P1. C2F. C2B. P1. K1. P2. (K1. P1) twice. P1. Rep from * to * twice. K1. P1. C2F. C2B. P1. K1. P2. (K1. P1) twice. P1. Rep from * to * once. K1. P1. C2F. C2B. P1. K1. P1. (P1. K1) 1 (3-4-5) time(s).

5th row: As 1st row.

7th row: (K1. P1) 1 (3-4-5) time(s). P1. *K1. P1. C2F. C2B. P1. K1. P1. K12. P1.* K1. P1. C2F. C2B. P1. K1. P2. (K1. P1) twice. P1. Rep from * to * twice. K1. P1. C2F. C2B. P1. K1. P2. (K1. P1) twice. P1. Rep from * to * once. K1. P1. C2F. C2B. P1. K1. P1. (P1. K1) 1 (3-4-5) time(s).

9th row: As 1st row.

11th row: As 7th row.

12th row: As 2nd row.

These 12 rows form pat.

Cont in pat until work from beg measures 18 ins [45.5 cm] ending with RS facing for next row.

Armhole shaping: Keeping cont of pat, cast off 4 (6-7-8) sts beg next 2 rows.

Dec 1 st each end of needle on next and following alt rows 4 (6-7-8) times. 114 sts.

Cont even in pat until armhole measures 9 (9½-10-10½) ins [23 (24-25-26) cm] ending with RS facing for next row.

Shoulder shaping: Cast off 17 sts beg next 2 rows, then 18 sts beg following 2 rows. Cast off rem 44 sts.

LEFT FRONT

**With smaller needles cast on 49 (53-55-57) sts.

1st row: (WS). Knit.

Cont in garter st until work from beg measures 2 ins [5 cm] ending with RS facing for next row and inc 13 sts evenly across last row. 62 (66-68-70) sts.**

Change to larger needles and proceed in pat as follows:

1st row: (RS). (K1. P1) 1 (3-4-5) time(s). P1. *K1. P1. C2B. C2F. P1. K1. P1. K12. P1.* K1. P1. C2B. C2F. P1. K1. P2. (K1. P1) twice. P1. Rep from * to * once.

2nd and alt rows: *K1. P12. K1. P1. K1. P4. K1. P1.* (K1. P1) 4 times. K1. P4. K1. P1. Rep from * to * once. K1. (P1. K1) 1 (3-4-5) time(s).

3rd row: (K1. P1) 1 (3-4-5) time(s). P1. *K1. P1. C2F. C2B. P1. K1. P1. C6B. C6F. P1.* K1. P1. C2F. C2B. P1. K1. P2. (K1. P1) twice. P1. Rep from * to * once.

5th row: As 1st row.

7th row: (K1. P1) 1 (3-4-5) time(s). P1. *K1. P1. C2F. C2B. P1. K1. P1. K12. P1.* K1. P1. C2F. C2B. P1. K1. P2. (K1. P1) twice. P1. Rep from * to * once.

9th row: As 1st row.

11th row: As 7th row.

12th row: As 2nd row.

These 12 rows form pat.

Cont in pat until work from beg measures 18 ins [45.5 cm] ending with RS facing for next row.

Armhole shaping: Keeping cont of pat, cast off 4 (6-7-8) sts beg next row.

Work 1 row even in pat.

Dec 1 st at armhole edge on next and following alt rows 0 (1-3-3) time(s). 57 (58-57-58) sts.

Work 1 row even in pat.

Neck shaping: Next row: (RS).

Work 2tog. Pat to last 2 sts. Work 2tog (neck edge).

Work 1 row even in pat.

Rep last 2 rows 3 (4-3-4) times more. 49 (48-49-48) sts.

Dec 1 st at neck edge only on next and following alt rows until there are 38 (40-40-40) sts, then every following 4th row until there are 35 sts.

Cont even in pat until work from beg measures same length as Back to beg of shoulder shaping ending with RS facing for next row.

Shoulder shaping: Cast off 17 sts beg next row. Work 1 row even. Cast off rem 18 sts.

RIGHT FRONT

Work from ** to ** as given for Left Front.

Change to larger needles and proceed in pat as follows:

1st row: (RS). *P1. K12. P1. K1. P1. C2B. C2F. P1. K1.* P2. (K1. P1) twice. P1. K1. P1. C2B. C2F. P1. K1. Rep from * to * once more. P1. (P1. K1) 1 (3-4-5) time(s).

2nd and alt rows: (K1. P1) 2 (4-5-6) times. K1. P4. K1. P1. K1. P12. K1. P1. K1. P4. (K1. P1) 5 times. K1. P4. K1. P1. K1. P12. K1.

3rd row: *P1. C6B. C6F. P1. K1. P1. C2F. C2B. P1. K1.* P2. (K1. P1) twice. P1. K1. P1. C2F. C2B. P1. K1. Rep from * to * once more. P1. (P1. K1) 1 (3-4-5) time(s).

5th row: As 1st row.

7th row: *P1. K12. P1. K1. P1. C2F. C2B. P1. K1.* P2. (K1. P1) twice. P1. K1. P1. C2F. C2B. P1. K1. Rep from * to * once more. P1. (P1. K1) 1 (3-4-5) time(s).

9th row: As 1st row.

11th row: As 7th row.

12th row: As 2nd row.

These 12 rows form pat.

Cont in pat until work from beg measures 18 ins [45.5 cm] ending with **WS** facing for next row.

Armhole shaping: Keeping cont of pat, cast off 4 (6-7-8) sts beg next row.

Dec 1 st at armhole edge on next and following alt rows 0 (1-3-3) time(s). 57 (58-57-58) sts.

Work 1 row even in pat.

Neck shaping: Next row: (RS). Work 2tog (neck edge). Pat to last 2 sts. Work 2tog.

Work 1 row even in pat.

Rep last 2 rows 3 (4-3-4) times more. 49 (48-49-48) sts.

Dec 1 st at neck edge only on next and following alt rows until there are 38 (40-40-40) sts, then every following 4th row until there are 35 sts.

Cont even in pat (as placed in last 6 rows) until work from beg measures same length as Back to beg of shoulder shaping ending with **WS** facing for next row.

Shoulder shaping: Cast off 17 sts beg next row. Work 1 row even. Cast off rem 18 sts.

SLEEVES

With smaller needles cast on 43 (45-45-47) sts.

1st row: (WS). Knit.

Cont in garter st for 2 ins [5 cm] ending with RS facing for next row and inc 19 (21-21-23) sts evenly across last row. 62 (66-66-70) sts.

Change to larger needles and proceed in pat as follows:

1st row: (RS). P1. (K1. P1) 2 (3-3-4) times. (K1. P1. C2B. C2F. P1. K1. P1. K12. P1) twice. K1. P1. C2B. C2F. (P1. K1) 3 (4-4-5) times. P1.

2nd row: P1. (K1. P1) 1 (2-2-3) time(s). K2. (P1. K1. P4. K1. P1. K1. P12. K1) twice. P1. K1. P4. K1. P1. K2. (P1. K1) 1 (2-2-3) time(s). P1.

3rd row: P1. (K1. P1) 2 (3-3-4) times. (K1. P1. C2F. C2B. P1. K1. P1. C6B. C6F. P1) twice. K1. P1. C2F. C2B. (P1. K1) 3 (4-4-5) times. P1.

4th row: As 2nd row.

5th row: As 1st row.

6th row: As 2nd row.

Pat is now in position.

Cont in pat inc 1 st each end of needle on next and following 6th rows until there are 90 (92-94-96) sts, taking inc sts into side pat. Cont even in pat until work from beg measures 17½ (18-18½-18½) ins [44.5 (45.5-47-47) cm] ending with RS facing for next row.

Shape top: Keeping cont of pat, cast off 2 (3-3-4) sts beg next 2 rows.

Dec 1 st at each end of next and following alt rows until there are 80 (76-74-70) sts, then on every row until there are 20 (20-24-24) sts. Cast off.

FINISHING

Pin garment pieces to measurements. Cover with a damp cloth leaving to dry.

Button and Buttonhole Band:

Sew shoulder seams. With smaller needles cast on 11 sts.

1st row: (WS). Knit.

Cont in garter st until band, when slightly stretched, measures length to fit up Left Front edge to first front dec, sewing in place as you work, ending with RS facing for next row and placing markers for 5 buttons on this band, having top button $\frac{1}{2}$ inch [1 cm] below first neck dec, bottom button $\frac{1}{2}$ inch [1 cm] above lower edge and rem 3 buttons spaced evenly between.

Shape Collar: Inc 1 st at beg (neck edge) of next and following alt rows until there are 41 (43-43-45) sts (Collar should now reach Left Front shoulder seam when slightly stretched).

Cont even until Collar measures length to fit across Back neck edge when slightly stretched, ending with RS facing for next row.

Dec 1 st at beg (neck edge) of next and following alt rows until there are 11 sts (Collar should now reach first neck dec on Right Front).

Cont even until Band measures length to fit down front edge to lower edge, working buttonholes to correspond to button markers as follows:

1st row: (RS). K4. Cast off 2 sts. Knit to end of row.

2nd row: Knit, casting on 2 sts over cast off sts.

Sew buttons to correspond to buttonholes.

Sew side and sleeve seams. Sew in sleeves.

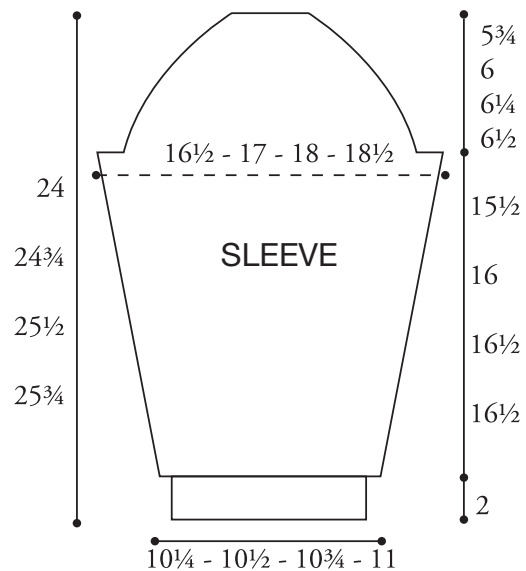
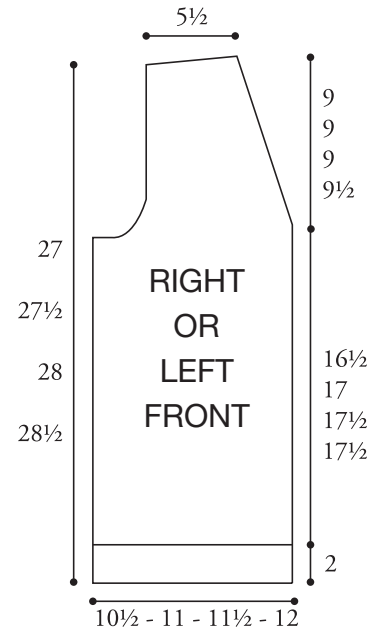
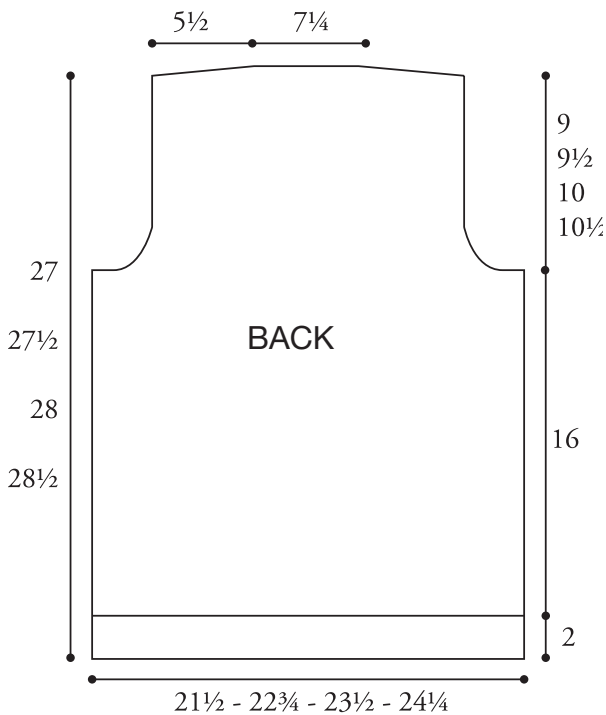

Patons

... a part of your life.

P.O. Box 40, Listowel ON N4W 3H3